

A NOVEL WFS BASED MULTI PORT DC- DC CONVERTER WITH MINIMAL SWITCHING DEVICES

P.Priyanka

Assistant professor, Department of EEE
St. Martin's Engineering College
Dhulapally, Secunderabad, Telangana
priyaparankusham@gmail.com

Dr.P.Santosh Kumar Patra

Principal & Professor in CSE
St. Martin's Engineering College
Secunderabad-500100, India
drpskpatra@gmail.com

Abstract: *This paper proposes a Renewable WFS Based Multiport Dc-Dc Converter with tri input of wind, fuel, solar cell and dual output in case 1 and in case 2 tri input of wind, fuel, solar cell and single output. As the conventional sources are tends to depleting, the alternative ways are chosen to generate electrical power nothing but non-conventional energy sources. Energy conversion always involves a DC section. So it is mandatory to focus on the DC-DC converters. As huge progress takes place in power electronics field, multiport converters are one of the greatest deals. It treats the whole system as a single power converter, gives high efficiency. Multiport dc-dc converters are compact in structure with fewer components, lower cost compared to numerous DC-DC converters. The existing topology of the multiport DC-DC Converter used four switches but the proposed topology used only two switches results in reduction of switching losses and the output voltages are high and regulated. The closed loop PI controlling strategy is adopted. The results were verified by using MATLAB simulink Software.*

Key words: *WFS, Multiport, tri input, Dual Output, single output, Dc-Dc Converter.*

I.INTRODUCTION

The generation, transmission, distribution and utilization of electrical energy is called a power system. The three main sources of power system are: Thermal power, Hydro-electric power, Nuclear power. The fuel used here are coal, petroleum, natural gas, uranium etc. are called conventional energy sources (or) non-renewable energy sources. These sources are depleting day by day and these are severe threat to nature because they cause many climatic problems such as green house effect, global warming, acid rains, ozone layer depletion etc. So it is imperative to depend upon alternate energy sources such as non-conventional energy sources (or) renewable energy sources. The examples of renewable energy

sources are: Solar energy, Wind energy, Tidal energy, geothermal energy, Biogas, Biomass etc.

In the renewable energy sources power generation plants and in electric drive unit, energy conversion always involves a DC section. So it is mandatory to focus on the dc-dc converters. DC-DC converters converts fixed direct voltage to variable/controllable direct voltage. These are of three types namely buck, boost and buck-boost converter. For an input voltage buck converter gives lesser output voltage, boost converter gives higher output voltage and buck-boost converter gives either lesser or higher output voltages than the input voltage.

Alessio Clerici, et.al [1] discussed that the major consumer of electricity is public transportation systems. As the train power demand increasing relevantly is creating interest in energy savings. Whatever the energy is getting from the braking system, it has to be reinjected to the ac network but it is quite difficult. So Multiport converters are the good solution for the above problem.

Hongfei wu, et.al [2] suggested that now a day for power systems energy storage system plays a vital role. In order to interface the AC grid and energy storage devices bidirectional AC-DC converter plays key role. But the major challenge to the engineers is efficient and flexible energy swapping between AC grid and energy storage devices. It is achieved through the three-port converter.

Amit Bhattacharjee, et.al [3] proposed the different topologies for integration of Photo voltaic cells with storage elements. For this purpose multiport converter is utilized. It not only provides the single stage power conversion but also gives unique characteristics, such as Maximum power point tracking for Photo Voltaic cells and charging, discharging capability for storage elements especially batteries.

Amir Ganjavi, et.al [4] proposed that simultaneous regulated output voltage is obtained by the integrated three-level buck and boost converters. For this purpose high-efficiency multiport dc-dc converter is designed.

Sunny H.Kung, Gregory J. Kish [5] suggested that, To transfer the bulk amount of power through long distances with less losses, more reliability, low cost ; DC transmission is preferable than AC transmission. So the Multiport high voltage DC-DC converters are required to facilitate future High voltage direct current transmission. To manage the power flow multiport modular multilevel converter is used.

Mohammad Sameer Irfan, et.al [6] proposed that a power-decoupling control scheme using a multiport isolated bidirectional converter for a multilevel inverter. A single power-decoupling capacitor is required for all the dc links in the multilevel inverter. In order to improve the lifetime and reliability, Film capacitors have to be used instead of the electrolytic ones.

Mohammed Alsolami, et.al [7] suggested that UPS systems are designed to provide good, conditioned, and uninterruptible power to key equipment such as computers, medical equipment, storage devices, and various industrial equipment. The main contribution is good load protection combined with a highly efficient operation in normal mode and seamless transfer power to the backup mode.

Baburaj Karanayil, et.al [8] proposed an electrical aircraft design in which conventional devices are replaced by electrical systems. In this a power flow management system for electric aircraft by integrating an isolated multiport bidirectional power converter with three HVDC buses are used. One of the most recent commercial transport aircraft Boeing 787 is used.

Chun Gan, et.al [9] addressed a multiport bidirectional switched reluctance motor drive for solar-assisted hybrid electric bus power train, improves the motoring performance and achieves reliable charging functions. Photovoltaic panels are installed on the vehicle such as bus and autonomous-charging capability.

Matteo Corti, et.al [10] proposed that DC systems which involve energy storage devices, non conventional energy sources, loads, and front-end converters can provide some advantages as Compared with ac grid. The interruption of fault currents in dc is tedious due to non-zero crossing of the current. However the DC circuit breakers take more time to clear the fault while protecting switching components. Multiport converters are an appropriate solution for solving the above problem.

Fan Yi, Wen Cai [11] presented a quasi-Z-source integrated multiport converter to enable wide-speed range operation of switched reluctance motor. With switch multiplexing technique, ripples in the power are reduced using a small capacitor.

Fan Yi, Wen Cai [12] proposed a control method for switched reluctance motor drives based on integrated multiport power converter. These are run by batteries; Due to the current commutation technique a large power ripples are formed. It is the most challenge issue for Switched reluctance motor drives.

Wen Cai, Fan Yi [13] presents the switched reluctance motor is based on an asymmetrical H-bridge. It requires a large capacitor on the dc bus to absorb the transient energy caused by current commutation. It consists of a multiport converter which introduces the dc bus capacitor as a surplus port in addition to the input port and switch multiplexing technique is used for its integration.

Mihaescu Mihai [14] proposed that the multiport converters have multi input and output ports to which multi supplies and loads can be connected. The entire system is very simple and compact due to multiport structure.

Erdem Asa, et.al [15], phase shift between ports maintained power flow and duty cycle with assymetricity handles the output voltage. The transformers are connected in Series at the secondary side enable to split the power and reduce the stresses on the switches. Comparatively it is not possible with parallel connected transformers.

Kenichi Itch, et.al, [16], the circuit is the integration of two multiphase converters and one isolated dc-dc converter. By adjusting the duty cycle ratio and phase angle difference these converters are controlled individually. It consists of four ports in the circuit, and the Power can be delivered multidirectional among those ports.

Hongfei Wu, et.al [17], multiport converter based on the dc-link inductor concept is proposed in this paper. Multiple pulsating voltage cells should be interconnected through the DC link inductors to generate multi-port converter. The pulsating voltage cells are of three types such as input, output and bidirectional. If all the pulsating voltage cells are bidirectional, multiport bidirectional topologies can be developed.

Joshua T. Hawke, et.al [18] proposed that to generate the power from fuel cells, multiport converter topologies are beneficial. Multiple fuel cells are connected to a medium voltage grid through a neutral point inverter and it should be isolated with high-frequency.

Venmathi M. and Ramaprabha R. [19] proposed that a multiport converter is nothing but a frequency link ac converter contains energy sources, energy storage devices and the load. To maintain the power balance in the system there should be a bidirectional-flow.

As from the literature most of the topologies used many switches which lead to the increase in switching losses and the topologies are also complex. Moreover ,these converters are used to drive the machines like switched reluctance motors for different applications. The usage of large number of switches leads to the heating and produce the switching stresses. These may cause the malfunctioning of drives and affect its performance.

Advantages of WFS: These are sustainable, Provides clean energy, Does not because environmental problems, Operational cost are less.

Disadvantages of WFS: Cost of installation is more; it is difficult to meet the people’s demand because of its inconsistency and unreliability, less efficient.

But as an engineer it is responsible to overcome the above disadvantages due to WFS. This project proposes to use the WFS to meet the future demand. Here the power electronics plays a vital role.

By considering all the above mentioned issues, this paper proposes a multiport converter. It consists of multiple input and output ports. Wind, fuel cell and solar cell are given to input ports. Load is taken from output port. Battery is given to one more Port. A suitable control strategy is mandatory to maintain the power flow between the ports. Because in case of shortage of supply battery will maintain the load. If the supplied power is more than the demand, battery will consume the power. In this way the power balance is maintained in the system.

II.METHODOLOGY

2.1Single input dual output dc-dc converter with four switches:

The fig.1 shows the single input dual output dc-dc converter with four switches as proposed in [4].It consists of a dc input source, four power switches, two blocking diodes, three filter components for step up and step down outputs and passive components.

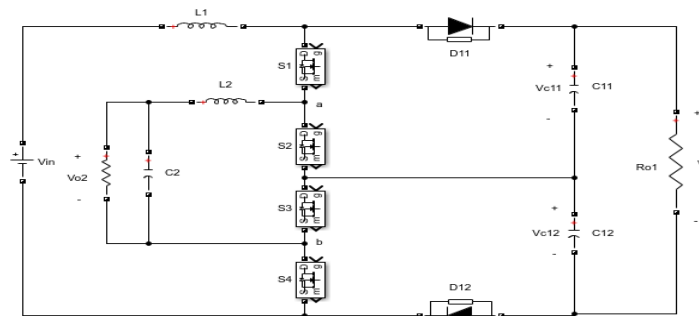

Figure 1: Single input dual output DC-DC converter with four switches

Two switches are given the duty cycle greater than the 50% and the two switches are given the duty cycle lesser than the 50% to get step up and step down outputs respectively. It consists of sixteen switching states because more number of switching states cannot produce same output voltages, but also not having the same charging states. In turn they have similar equivalent circuits which are identical.

2.2 Proposed Topology

Case: 1with two switches, two outputs

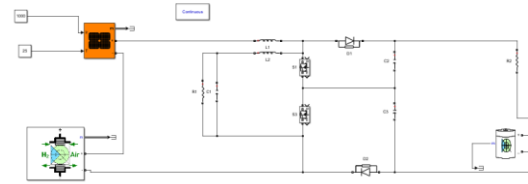

Figure 2: With two switches, two outputs

The above fig 2 shows the circuit diagram of two input dual output with two switches. It consists of input as a renewable energy sources i.e. solar and fuel cell. Two inductors L_1 and L_2 ; two resistors R_{o1} and R_{o2} ; filter capacitors C_{11} and C_{12} of boost 230W.Two inductors L_1 and L_2 ; two resistors R_{o1} and R_{o2} ; filter capacitors C_{11} and C_{12} of boost power switches. D_{11} and D_{12} are the power diodes.

Case: 2with one switch, one output

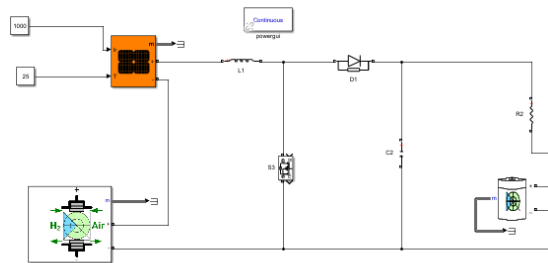

Figure 3: with one switch, one output

The above fig 3 shows the circuit diagram of two input dual output with one switch. It consists of input as a renewable energy sources i.e. solar and fuel cell. One inductor L_1 ; one resistor R_2 ; filter capacitors C ; S_1 is the one power switch. D_1 power diode.

III.SIMULATION CIRCUIT

EXISTING SYSTEM

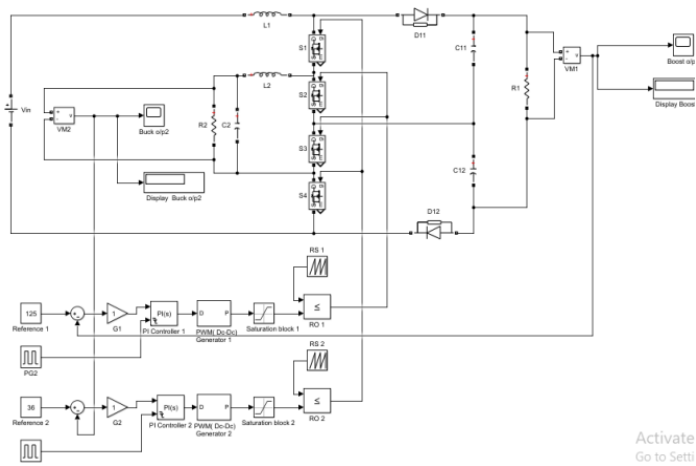

Figure 4: Simulink diagram of Existing topology

The duty cycles of the two switches are same and for remaining two switches are same. Two saw tooth carrier signals are used.

The duty cycle of S1, S4 is lesser than 50% and for S2; S3 is greater than 50%.

These two duty cycles are the control parameters of step up and step down voltages.

Formula for duty cycle: $V_o = D / (1-D) V_{in}$

Two proportional-integral (PI) controllers are used to get the regulated output voltages.

PROPOSED SYSTEM

Simulink diagram of proposed system for case 1

The duty cycles of the two switches are different. Two saw tooth carrier signals are used.

The duty cycle of S1 is lesser than 50% and for S2 is greater than 50%.

These two duty cycles are the control parameters of step up and step down voltages.

Formula for duty cycle: $V_o = D / (1-D) V_{in}$

Two proportional-integral (PI) controllers are used to get the regulated output voltages.

The step-up output voltage is compared with ref 2 and step down output voltage is compared with ref1.

Kp and ki are calculated by using Ziegler Nicholas chart, as it is a traditional method.

The values of kp and ki are 5.4 and 1.488.

The simulink diagram is shown in fig: 5

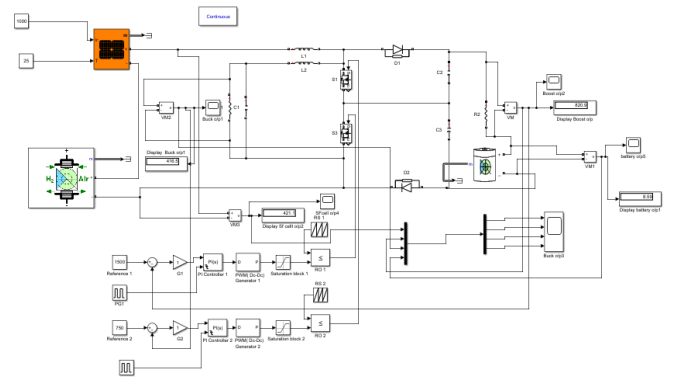

Figure 5: Simulation Diagram of Proposed Circuit of case 1

Simulink diagram of proposed system for case 2

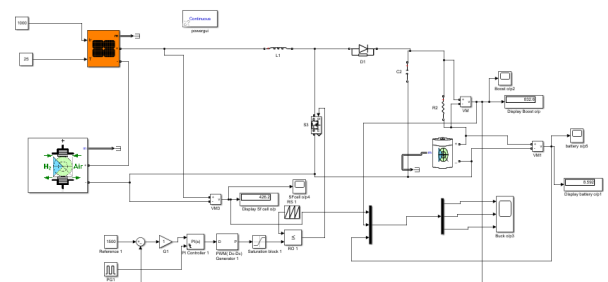

Figure 6: Simulation Diagram of Proposed Circuit of case 2

The duty cycle of only one switch is considered. One saw tooth carrier signal is used.

The duty cycle of S1 is greater than 50%.

This duty cycle is the control parameter of step up voltage.

Formula for duty cycle: $V_o = D V_{in}$

One proportional-integral (PI) controller is used to get the regulated output voltage; the step-up output voltage is compared with reference.

Kp and ki are calculated by using Ziegler Nicholas chart, as it is a traditional method.

The values of kp and ki are 5.4 and 1.488.

IV.RESULTS DISCUSSION

This part discusses the results obtained from the Mat lab.

1. GRAPHS FOR EXISTING SYSTEM

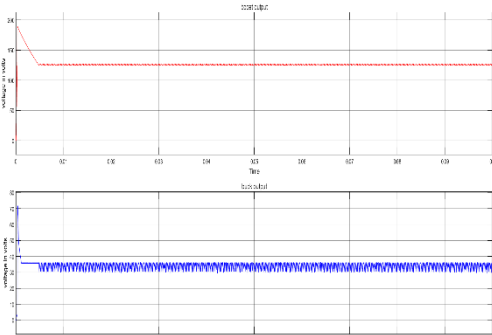

Fig 7:graph for single input dual output with four switches

Fig.7 shows the graph for four switch topology with PI controller. For an input of 60V, step-up voltage of 125V and step down voltage of 36V are obtained.

2. GRAPHS FOR PROPOSED SYSTEM (WITH TWO SWITCH TWO OUTPUT)

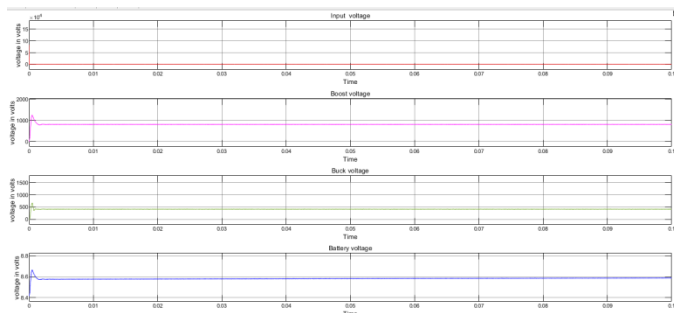

Figure 8: Graph for dual input dual output with two switch topology

The above Graph: shows the dual input dual output with two switch topology.

For an input voltage of 420V from the solar- fuel cell, the step-up output voltage obtained is 820.9V, the step-down output voltage is 416.5V, and battery voltage is 8.59V.

3. GRAPHS FOR PROPOSED SYSTEM (WITH ONE SWITCH ONE OUTPUT)

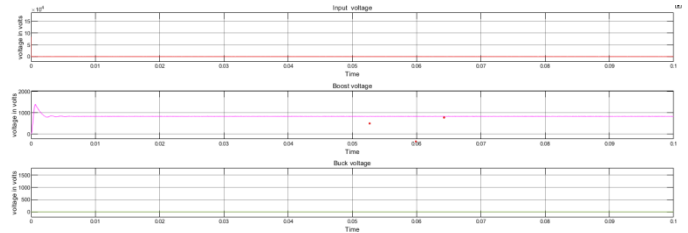

Figure 6: single input single outputs with one switch topology

The above fig.9 shows the graph of the topology of one switch one output.

For an input voltage of 420V from the solar-fuel cell, the output voltage obtained is 832.6V and the battery voltage is 8.59V.

Comparison of results of the existing and proposed systems

S.no	Parameter	Existing System	Proposed system	
			Case:1	Case:2
1.	Source	Dc source	WFS	WFS
2.	Switch	Four(4)	Two(2)	One(1)
3.	Step-up output	125V	820.9V	832.6 V
4.	Step-down output	36V	416.5V	-

Table: comparisons of results of the existing and proposed systems

V. CONCLUSION

This paper proposed a WFS Multiport Dc-Dc Converter with 1. minimum number of switches. The existing system used a four 2. switches leads to the more switching losses where as the 3. modified system used only two switches which results in improvement of voltage, reduction of switching losses and the ripples got reduced slightly. The modified circuit consists of only two switches which reduces the cost of circuit due to its compactness. Hence the comparison between the two systems clearly reveals the improvement of efficiency and output voltage of proposed topology of dual input dual output dc-dc converter. The output voltages are 820.9V for case 1 and 832.6V for case 2, are used for high voltage applications.

VI. REFERENCES

1. Clerici, A., Tironi, E., & Castelli-Dezza, F. (2018). Multiport converters and ESS on 3-kV DC railway lines: Case study for braking energy savings. *IEEE Transactions on Industry Applications*, 54(3), 2740-2750.
2. Wu, H., Zhu, L., & Yang, F. (2018). Three-Port-Converter-Based Single-Phase Bidirectional AC-DC Converter with Reduced Power Processing Stages and Improved Overall Efficiency. *IEEE Transactions on Power Electronics*, 33(12), 10021-10026.
3. Bhattacharjee, A. K., Kutkut, N., & Batarseh, I. (2019). Review of Multiport Converters for Solar and Energy Storage Integration. *IEEE Transactions on Power Electronics*, 34(2), 1431-1445.
4. Ganjavi, A., Ghoreishy, H., & Ahmad, A. A. (2018). A Novel Single-Input Dual-Output Three-Level DC-DC Converter. *IEEE Transactions on Industrial Electronics*, 65(10), 8101-8111.
5. Kung, S. H., & Kish, G. J. (2019). Multiport Modular Multilevel Converter for DC Systems. *IEEE Transactions on Power Delivery*, 34(1), 73-83.
6. Irfan, M. S., Ahmed, A., & Park, J. H. (2018). Power-decoupling of a multiport isolated converter for an electrolytic-capacitor less multilevel inverter. *IEEE Transactions on Power Electronics*, 33(8), 6656-6671.
7. Alsolami, M., Potty, K. A., & Wang, J. (2017). A gallium-nitride-device-based switched capacitor multiport multilevel converter for UPS applications. *IEEE Transactions on Power Electronics*, 32(9), 6853-6862.
8. Karanayil, B., Ciobotaru, M., & Agelidis, V. G. (2017). Power flow management of isolated multiport converter for More electric aircraft. *IEEE Transactions on Power Electronics*, 32(7), 5850-5861.
9. Gan, C., Jin, N., Sun, Q., Kong, W., Hu, Y., & Tolbert, L. M. (2018). Multiport bidirectional SRM drives for solar-assisted hybrid electric bus power train with flexible driving and self-charging functions. *IEEE Transactions on Power Electronics*, 33(10), 8231-8245.
10. Corti, M., Tironi, E., & Ubezio, G. (2016). DC networks including multiport DC/DC converters: Fault analysis. *IEEE Transactions on Industry Applications*, 52(5), 3655-3662.
11. Yi, F., & Cai, W. (2016). A quasi-Z-source integrated multiport power converter as switched reluctance motor drives for capacitance reduction and wide-speed-range operation. *IEEE Transactions on Power Electronics*, 31(11), 7661-7676.
12. Yi, F., & Cai, W. (2016). Modeling, control, and seamless transition of the bidirectional battery-driven switched reluctance motor/generator drive based on integrated multiport power converter for electric vehicle applications. *IEEE Transactions on Power Electronics*, 31(10), 7099-7111.
13. Cai, W., & Yi, F. (2016). An integrated multiport power converter with small capacitance requirement for switched reluctance motor drive. *IEEE transactions on power electronics*, 31(4), 3016-3026.
14. Mihai, M. (2015, June). Multiport converters-a brief review. In *2015 7th International Conference on Electronics, Computers and Artificial Intelligence (ECAI)* (pp. P-27). IEEE.
15. Asa, E., Colak, K., Bojarski, M., & Czarkowski, D. (2015). Asymmetrical duty-cycle and phase-shift control of a novel multiport CLL resonant converter. *IEEE Journal of Emerging and Selected Topics in Power Electronics*, 3(4), 1122-1131.
16. Itoh, K., Ishigaki, M., Yanagizawa, N., Tomura, S., & Umeno, T. (2015). Analysis and design of a multiport

converter using a magnetic coupling inductor technique. *IEEE Transactions on Industry Applications*, 51(2), 1713-1721.

17. Wu, H., Zhang, J., & Xing, Y. (2015). A family of multiport buck–boost converters based on DC-link-inductors (DLIs). *IEEE Transactions on power electronics*, 30(2), 735-746.

18. Hawke, J. T., Krishnamoorthy, H. S., & Enjeti, P. N. (2014). A family of new multiport power-sharing converter topologies for large grid-connected fuel cells. *IEEE Journal of Emerging and Selected Topics in Power Electronics*, 2(4), 962-971.

19. Venmathi, M., & Ramaprabha, R. (2013). A comprehensive survey on multi-port bidirectional DC–DC converters for renewable energy systems. *ARPJ Eng Appl Sci*, 8(5), 348-56.